

Chapter Three

Introduction to Solar Electric Systems

In 1954 scientists at Bell Laboratories introduced the first photovoltaic cells that produced useable amounts of electricity directly from sunlight. Since that time the use of photovoltaics has grown exponentially and spread throughout the world. The initial phase of research and development of photovoltaic (PV) technology was driven by the US space program, which developed PVs as a power source for satellites in outer space. Today, PVs are used in a wide range of applications, ranging from common consumer products like calculators, to systems that power entire homes and communities.

PV cells do not use the sun's heat to produce electricity. They produce electricity directly when sunlight interacts with semiconductor materials in the PV cells and they work whenever they are exposed to the sun. They produce more electricity when the sunlight is more intense (on a sunny rather than a cloudy day) and when the light strikes the PV cells directly (when the rays of sunlight are perpendicular to the PV cell). PV electricity output is also greater when cells are cold, and reduced when cells are hot. A PV panel (also known as a "module") consists of a number of cells linked together to provide power suitable for charging batteries or running loads directly (see Figure 3.1). Shading greatly reduces the power output from PV cells and panels. In fact, if only one cell in a PV panel is shaded, it can rob the energy from the rest of the cells in the panel. This is a very important factor when designing PV systems and special attention is given to preventing things like tree limbs and overhead wires from shading even a small portion of a PV panel. In contrast, partial shading is not as significant for solar water heater collectors. A PV panel with 50 percent of its surface shaded will produce virtually no electricity,

whereas a solar water heater will still produce about 50 percent of its rated output with 50 percent of its surface shaded. As a result, solar water heaters can be mounted behind deciduous trees and still function effectively, so long as the trees only shade the collectors when their leaves are off. It generally would not be appropriate to put PV panels in such a location.

The Photovoltaic Cell

"A typical PV cell made of crystalline silicon is 12 centimeters in diameter and 0.25 millimeters thick. In full sunlight, it generates 4 amperes of direct current at 0.5 volts or 2 watts of electrical power. PV modules consist of PV cells connected in series (to increase the voltage) and in parallel (to increase the current), so that the output of a PV system can match the requirements of the load to be powered. If more power is required, modules can be appropriately connected in series or parallel to form what is called a PV array (see Figure 3.1). Thin film PV cells are newer forms of PV with different semiconductor materials, geometries, and dimensions but the series and parallel connection of thin film cells and modules is similar to crystalline PV."¹



Figure 3.2: A PV Cell
Office of Energy Efficiency and Renewable Energy, US DOE

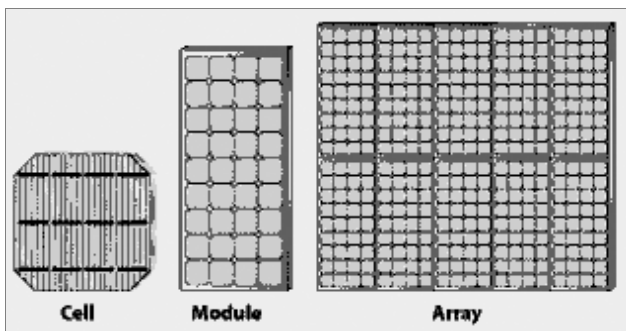

Figure 3.1: PV cells are combined to create PV modules, which are linked to create PV arrays.
Office of Energy Efficiency and Renewable Energy, US DOE

Trends in the Photovoltaics Industry

The global photovoltaics industry has undergone rapid expansion. Solar and wind power generation capacity have each grown by an average of more than 30 percent per year over the past five years. The solar photovoltaics (PV) industry grew to more than 700 MW of new solar PV manufacturing output in 2003, up from about 500 MW the year before.²

At a conservative 20 percent rate of growth each year, PV production worldwide would amount to 2.5 gigawatts in 2010, and 15.5 gigawatts by the year 2020. As of January 2005, there was such a demand for PV panels that most orders have a two- to three-month waiting period. In October 2003, SHARP opened its first PV plant outside of Japan in Memphis, Tennessee. Sixty-seven people are directly employed at the plant.

Current annual PV production capacity at SHARP's new plant is 20 megawatts (MW). The total US market was 48 MW in 2002, and is estimated to be 120 MW by 2005.³

The popularity of net metering and other forms of distributed generation have affected the demand for solar photovoltaics. In 2002, 270 MW (51 percent) of PV shipments went into grid-intertied residential and commercial buildings. Even with the increased demand for PV, prices in mid-2004 were still lower than they had ever been, which reflects the progress that has been made in the manufacturing process. Much of this progress has been due to the support of the US Department of Energy's PV research program, and the industry has seen solar manufacturing prices fall by more than half in the last ten years.⁴

A plan developed by the Solar Energy Industries Association (SEIA) would utilize annually declining federal tax incentives to speed the commercialization of photovoltaics in the United States. According to SEIA's projections, implementing their plan would reduce the price of solar electricity from its current rate of 18 to 25 cents per kilowatt-hour to 5.7 cents per kilowatt-hour by 2015, thereby making it the least expensive retail electricity option. SEIA's *Photovoltaics Industry Roadmap* projects that this plan would generate more than \$34 billion in new manufacturing investments over the next ten years. By 2025, photovoltaics would provide half of all new electricity generation in the US, and by 2030, the US solar industry would employ 260,000 people.⁵

Environmental Costs of PV Systems

Photovoltaics can help us achieve a more sustainable energy system because they generate electricity using a renewable resource and without emitting pollutants. However, when we review the life cycle of a PV system from the manufacture of the PV cells and associated equipment, through installation, use, and final decommissioning or disposal, we find that their use is not without environmental costs. The greatest areas of environmental concern are associated with the energy required to manufacture and install PV equipment and the hazardous materials used to make PV cells and batteries.

Building and installing a PV system requires resources and energy, and it is necessary to know our return on this initial energy investment. The National Renewable Energy Laboratory (NREL) reviewed research into the "energy payback" of PV systems to assess how long they must operate to generate the amount of energy that was used to make and install the system. NREL reports that, depending on the type of PV cell being used, the energy payback for PV systems is one to four years. Assuming a 30-year operational life for PV systems, this means that 87 to 97 percent

of the energy they produce will be free of the environmental costs of the energy used in their manufacture.⁶

Numerous hazardous materials that could threaten the environment and human health are used in the manufacture of PV cells. These materials vary depending on cell type and include explosive and toxic gases, solvents, cadmium, and lead solder. After assessing the environmental and safety impacts of PV technology, the Brookhaven National Laboratories concluded that, "routine conditions in manufacturing facilities should not pose any threats to health and the environment" and that "the US industry is vigilant in preventing health risks and has established proactive programs in industrial hygiene and environmental control."⁷ They saw accidents at manufacturing plants as the greatest potential threat to workers and the surrounding human and natural communities.

Once installed, the PV module poses minimal health and environmental risks, according to the Electric Power Research Institute (EPRI). They state that "the potential for chemical releases appears to be small since the chemicals are present in the sealed PV modules. Releases are likely to occur only due to fires or other unusual accidents."⁸ At the end of a PV system's useful life, its disposal could contaminate the environment if it were landfilled or incinerated. The PV industry is currently developing processes for recycling old PV modules.⁹

Batteries, an integral part of many PV systems, present perhaps the most serious environmental and human health concerns. Batteries can contain lead, heavy metals, acids, and other hazardous chemicals, and their limited life spans (typically three to ten years) creates an ongoing demand for their production and disposal. The commonly-used deep cycle, lead-acid batteries require regular maintenance which may expose system users to hazardous chemicals. Although recycling rates for lead-acid batteries are high and new batteries contain, on average, 60 percent recycled lead,¹⁰ lead recycling has for the most part moved to Third World countries with lower wages and minimal or non-existent environmental and worker safety standards. Greenpeace has documented the flow of tens of thousands of tons of lead waste from the US, UK, Australia, and Japan to countries such as Indonesia, the Philippines, and Thailand. They have also documented the suffering of the workers and communities impacted by the lead smelters and recycling factories in these places.¹¹ The solar industry and renewable energy advocates should focus attention on this issue to motivate the lead and battery industries to meet the highest environmental and safety standards.

Despite the environmental costs of PV systems, solar electricity still offers distinct advantages that make it an important part of a renewable energy

economy. Compared to electrical generation from conventional fossil fuel power plants, "producing 1,000 kWh of electricity with solar power reduces emissions by nearly eight pounds of sulfur dioxide, five pounds of nitrogen oxides, and more than 1,400 pounds of carbon dioxide."¹² For a PV system that produces one-half of a modern household's electricity needs for 28 years, the system "would avoid conventional electrical plant emissions of more than half a ton of sulfur dioxide, one-third ton of nitrogen oxides, and 100 tons of carbon dioxide."¹³ As coal-burning power plants are the single largest source of mercury emissions in the United States, using solar electricity also prevents the emission of this highly toxic element.¹⁴ If a PV system displaces nuclear-generated power, it reduces the demand to operate and build new nuclear power plants.

Many of solar energy's benefits derive from the fact that it displaces the need for conventional, polluting energy sources. As we stressed in Chapter One, these benefits can be attained most cost-effectively and with the least environmental impact by implementing energy efficiency and conservation measures first. If you cut your utility bill by 50 percent, whether by means of a solar system, efficiency, or conservation, your reduced electrical demand reduces the need for power from the power plant. By itself this helps to slow growth in demand for new power plants. If enough households, businesses, and institutions were to significantly reduce their power needs, the accumulated reductions could even make it possible to shut down power plants. Remember, solar is a means, not an end. The ends are a cleaner environment, independence from fuel supplies that contribute to global conflicts, a safer energy supply, and a sustainable society.



Figure 3.3: This off-the-grid home in Rockcastle County, Kentucky is powered by the PV array in front of the house, *Andy McDonald*

Stand-Alone PV Systems

PV systems not connected to the electric utility grid are known as 'stand-alone systems.' Direct systems use the PV power immediately as it is produced, while battery storage systems can store energy to be used at a later time, either at night or during cloudy weather. Examples of direct systems are water pumps that operate during sunny days to fill storage tanks for later use, and ventilation fans that ventilate attics whenever the sun is shining. Battery storage systems often include an inverter to convert the PV-generated electricity from DC to AC, allowing standard AC (alternating current) appliances to be used. Having AC power available is convenient because AC appliances are more commonly available and are usually less expensive.

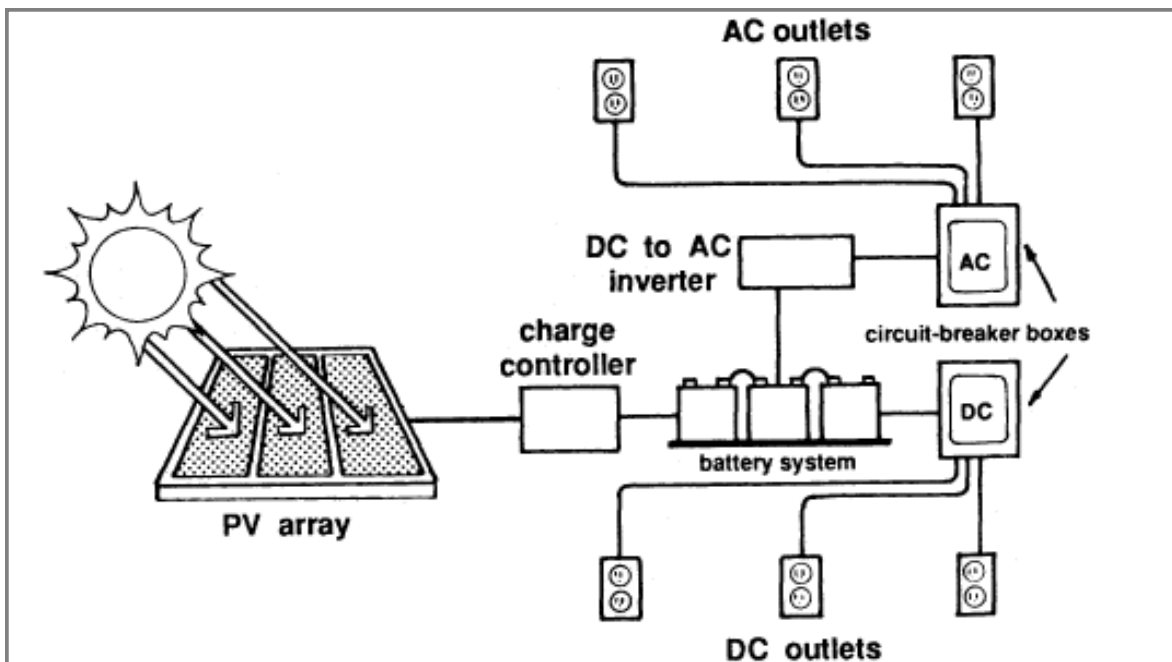

Figure 3.4: Stand-alone PV system, *North Carolina Solar Center*¹⁵

Applications for Stand-Alone PV Systems

Remote Site Electrification

- Rural homes, vacation cabins, hunting lodges
- Barns, outbuildings
- Visitor centers in parks, park ranger sites, campgrounds, public beach facilities
- Village/island electrification
- Health clinics and remote research facilities
- Electric fencing, farm workshops
- Highway rest stops
- Military test areas
- Refugee camps



Figure 3.5: Solar-charged electric fencing, Sureguard Fencing

Water Pumping and Control

- Livestock watering, irrigation
- Remote village water supplies
- Rural homes, campgrounds

Refrigeration for*

- Off-grid homes and facilities
 - Remote or mobile storage of medicines and vaccines
- * Refrigerators and freezers are well-suited to photovoltaics because they demand more power when more solar energy is available. At least one manufacturer, SunDanzer, produces a battery-free solar refrigeration system.¹⁶

Lighting

- Billboards, highway information signs
- Public facilities, parking lots, marinas, piers
- Homes, vacation cabins

Communications

- Radio, television, and telephone towers
- Traveler's information transmitters



- Portable computer systems, cellular phones, mobile radio systems
- Emergency call boxes

Figure 3.6: PV-powered water pumps provide water for livestock.

National Renewable Energy Laboratory

Remote Monitoring for

- Meteorological information, seismic recording
- Scientific research in remote locations
- Highway/traffic conditions, structural conditions
- Irrigation control

Signs and Signals

- Navigational beacons, lighthouses, buoys
- Railroad signals, highway signs, aircraft warning beacons

Charging Vehicle Batteries

- Direct charging electric vehicles, boats, recreational vehicles (RV's)
- "Trickle charging" little-used vehicles to maintain high battery state of charge, such as fire trucks, snow removal equipment, National Guard vehicles, and agricultural machines

Disaster Relief

- Providing power after natural disasters and extended power outages

Cathodic Protection (preventing corrosion of metals)

- Underground pipes, tanks, wellheads
- Wharves, bridges, buildings

Consumer Products

- Appliances for recreational vehicles
- Watches, calculators, lanterns, radios, televisions
- Flashlights, outdoor lights, security systems, gate openers
- Golf carts
- Attic fans, other types of fans

Building-Integrated Photovoltaics

- PV cells integrated into building materials such as roof shingles and windows

Adapted from "Photovoltaic Applications," North Carolina Solar Center at North Carolina State University, June 2002.



Figure 3.7: Building Integrated Photovoltaics (BIPV) can replace roofing shingles, as in this home.

www.stanford.edu/class/ee293a/BIPVlarge.html

Figure 3.4 illustrates the basic layout of a stand-alone system with battery storage, including both AC and DC circuits.

Stand-alone systems are used in a wide range of applications, especially in remote locations where access to the utility grid is unavailable. Due to the high cost of extending utility lines, PV systems commonly cost less than extending grid-power for sites located more than one-fourth mile from the nearest utility line.¹⁷ This is especially true for sites needing less power, where PV system cost is low relative to the high cost of power line extension. PV systems can also be the most economical option when a utility line would need to be buried beneath an existing hard surface, such as a road or sidewalk.

For large portable power needs (greater than 500 watts) or in remote locations, people commonly use diesel, gasoline, or propane generators. This option entails high maintenance costs along with the need to

purchase and transport fuel. As a fuel-free and low-maintenance power source, PV is an ideal alternative in these situations.¹⁸

Stand-alone PV systems can be coupled with conventional fossil fuel generators, wind electric generators, or micro-hydroelectric generators (which can generate electricity from pond overflows and streams). In such "hybrid" systems, the generator is only used to recharge the batteries during long periods of cloudy weather. This can provide peace of mind for people concerned about losing power during extended periods of bad weather. Such a system requires much less fuel and generator maintenance, and can extend the life of both the generator and the batteries. (In the case of wind and micro-hydroelectric generators, no fuel is required at all).

Stand Alone PV System with Backup Generator Powers Off-the-Grid Home

Wayne Allen's house, set on the edge of a sloping field encircled by woods, looks like a typical American home. If you were paying attention, you might notice that there are no power lines running to the house. That's because Wayne's house is powered by a 540-watt PV array, located across the stream on the south side of the house. Underground cables carry power from the shed where the batteries are stored into the house, preserving the view of the land. "This is such a beautiful place we have here," commented Wayne. "When my wife and I moved out here, we didn't want power lines ruining the view, so we asked the power company if they would bury the power lines. They refused to work with us, so we decided to put in a PV system instead."

The Allen's PV system uses two 120-watt and four 75-watt PV panels mounted on two separate posts. One of the mounts has a tracking mechanism that follows the sun throughout the day, enabling the panels to generate more power. The other mount is fixed facing due south. The system includes 16 golf cart batteries (Trojan T-105) and an inverter which provides AC power to the house. A back-up generator recharges the batteries when they get low, mainly during extended periods of cloudy weather in the winter. Wayne says he's never needed to recharge the batteries in the summertime, but occasionally it's needed in the winter. They also use the generator periodically in the summer to directly operate their air conditioner.

Wayne says he doesn't feel like he's sacrificing any comforts or conveniences to be living off-the-grid with a solar system. "We have all of the appliances people typically have," he said. "My wife and I watch TV and use the computer quite a bit. We have enough lighting and use ceiling fans. The PV system has met our needs just fine." They also use the PV system to pump water from their cistern. The PV system is supplemented by a propane refrigerator, water heater, and clothes dryer.

The Allen's have been very satisfied with the PV system since they installed it in 1999. "It's actually been less bothersome than I had expected," said Wayne. Adding water to the batteries a couple times per year has been about all the maintenance the system has required. Their batteries have begun to age, however, and are not holding a charge as long as they used to. They expect to replace the batteries in the near future.

The installed cost for the Allen's PV system was less than \$8,000, including labor and equipment. Wayne did most of the work himself, but hired an experienced PV installer (Joshua Bills) to help with some of the technical details. They are expecting to install an additional 360-watts of PV power in the coming year, and hope to some day install a solar water heater, as well.



Figure 3.8: The tracking array shown on the left follows the sun throughout the day, increasing power output, *Andy McDonald*

Grid-Intertied Systems and Net Metering

Grid-intertied (or utility-interactive) PV systems use the electric utility grid as a back-up power supply. The PV system is connected to the utility grid using a high quality inverter, which converts DC power from the solar array into AC power that conforms to the grid's electrical requirements. Connecting the PV system to the grid enables users to take power from the grid whenever they use more power than the PV system is generating (such as on cloudy days and at night). Any time the PV system generates more power than the building is using, the excess power is delivered back to the grid, rotating the electric meter *backwards*. This happens automatically through the inverter, which distributes the power to the loads in the house or to the grid, as needed.

In *net metering* arrangements, the customer-generator is credited for the amount of PV power they deliver to the grid. If during a billing period you consume more energy than you generate, you are billed for the *net* electricity consumed. If, on the other hand, you generate more energy than you consume during a billing period, you are *credited* for the *net* electricity generated, which is then used to offset the energy consumed during future billing periods.

Grid-intertied systems can be installed with or without a battery back-up. Having battery back-up provides power when the electric grid goes down. Systems without battery back-up are less expensive and require less maintenance than systems with batteries. However, they are also at the mercy of the grid. Should grid power fail, systems without batteries stop producing electricity regardless of whether the PV panels can produce power. This is necessary to protect electric line workers from unknown power sources. Systems with battery back-up automatically

transfer power from the grid to batteries when the grid fails.

Net Metering in Kentucky

Net metering in Kentucky started March 15, 2002 when the Kentucky Public Service Commission (PSC) approved a three-year pilot net metering program for Kentucky Utilities (KU) and Louisville Gas & Electric (LG&E). Union, Light, Heat, and Power (ULH&P) and Berea College Utilities soon followed suit with their own pilot net metering programs. KU and LG&E's pilot program allows net metering for solar, wind, and hydropower systems whose generating capacity is no greater than 10 kilowatts for residential customers and 25 kilowatts for commercial systems. The pilot programs are limited to 25 systems each for the KU and LG&E service areas. Participation in these pilot programs has been limited, due primarily to the large investment required for net metered systems, combined with the uncertainty of whether the programs would continue after the pilot period.

These pilot programs were followed by the passage of a statewide net metering bill, which was signed into law on Earth Day 2004. The Kentucky net metering law (unlike the pilot programs) allows net metering only for solar electric systems of 15 kilowatts or less. Every regulated utility in Kentucky (including Rural Electric Cooperatives), except for TVA (which has its own solar production incentive), is required to net meter customer solar generation. Unfortunately, municipal electric utilities are not regulated by the PSC, and thus are not included in the law. Typically, however, municipal electric utilities are more open to net metering than their investor-owned counterparts, so you may find them receptive to allowing net metered systems in your area.

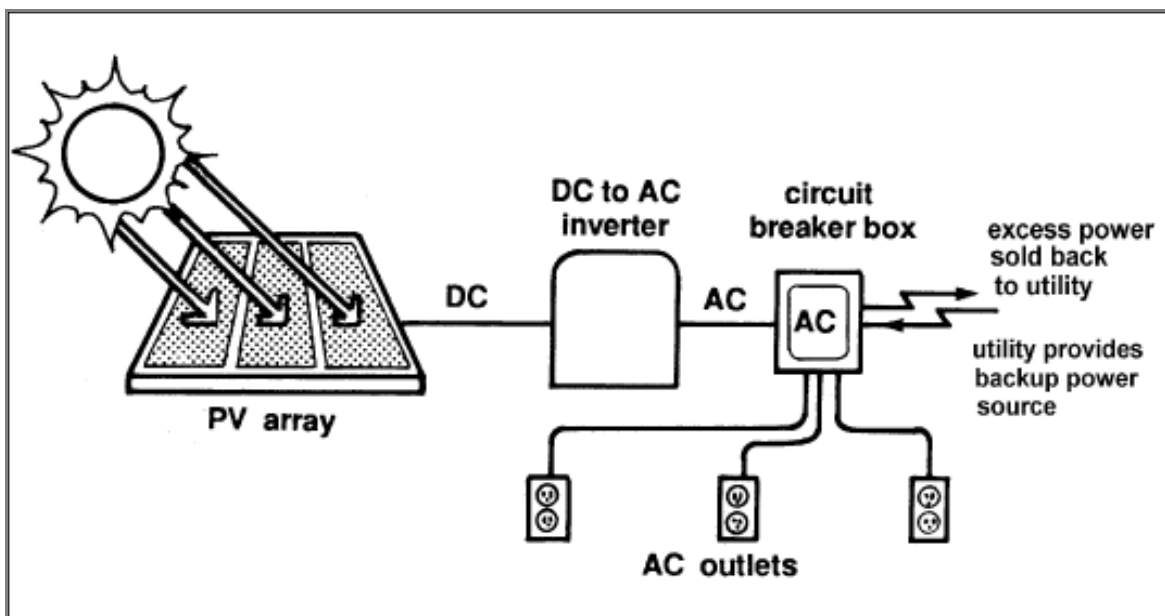

Figure 3.9: Utility-interactive PV system, North Carolina Solar Center¹⁹

Advantages of Net Metering

By permitting PV systems to legally tie into the electric grid and compensating system owners for the power they generate, net metering provides an important incentive for solar energy development. It helps people access the numerous advantages that net metered and grid-intertied systems have to offer.

One advantage of grid-intertied systems over stand-alone PV systems is that batteries are not required. This reduces the up-front cost of a grid-intertied system (compared to a similarly-sized stand-alone system) by about 20 percent. Eliminating the need for batteries also eliminates battery maintenance, the expense of periodically replacing them, and the environmental costs associated with them.

Another advantage of grid-intertied systems is that they maximize power production from the PV array, because all power generated is either used immediately on-site or flows into the grid, with credit going to the system owner for use anytime in the future. In this way all usable electricity from the PV array is utilized. This allows grid-intertied systems to be sized smaller and still provide as much usable energy as larger stand-alone, battery-based systems. Such stand-alone systems are often designed to meet demand in the winter when the available sunlight is at a minimum. This results in the system being over-sized for meeting summer demand. During the summer months most stand-alone systems generate more energy than the batteries can take in. Often batteries are full by 1:00 pm. The panels then stop charging the batteries and only generate as much power as the occupants are using at the time.

By contrast, all production from net-metered systems will either be used immediately on-site, or flow into the grid and be credited to offset future consumption. Should more energy be generated during a sunny summer billing period, a credit is given to the customer-generator which can be used to offset winter billing periods when more energy is consumed than

generated. Most state net metering laws allow credits to be carried forward for an annual period, after which they are given to the electric company or sold to them at a less-than-retail, avoided cost rate. The Kentucky net metering law is unusual in that credits are carried forward until the customer-generator uses them up or moves to another location.

Net metering can also benefit electric utilities whose peak demand is in the summer. Photovoltaics generate the most power on sunny summer days, when demand on the electric grid is often highest. With air conditioner use at its peak during the hot summer months, many electricity providers have to increase production in order to keep up with demand. Widely distributed PV systems could match this need, enabling utilities to avoid reliance on expensive peaking power generator systems.

"A major benefit of utility-interactive PV is that it can be widely distributed. This asset will lead to the installation of many small scale "distributed generation" power plants located on buildings. Over time, this could reduce the need for additional large centralized power plant construction and costly utility grid distribution network expansion. The nature of distributed generation can increase national energy security by increasing the number of power plants that would have to be targeted in order to shut down the national utility grid. Other examples of distributed generation technologies are wind turbines, fuel cells and micro turbines."²⁰

Many electric utilities now offer a green power choice for their customers. Not everyone wants to install a solar electric system on their rooftop or in their backyard. However, they might still consider paying an extra premium for "green power" from their utility company. Green power sources include landfill gas, wind, and solar energy. While utility-scale PV systems require a large initial investment, a network of net metered homes can supply utilities with a source of solar electricity for their green power programs.



Figure 3.10: This grid-intertied PV array at the office of Appalachia- Science in the Public Interest in Mt. Vernon Kentucky was one of the first net-metered systems in the state. The inverter is shown at left and the PV array above the entrance at right, *Andy McDonald*



Figure 3.11: PV panels double as roofing for this pavilion at the Lover's Lane soccer complex in Bowling Green, Kentucky, *Tennessee Valley Authority*

Utilities gain by tracking the output from their customer's net metered systems, which they then can sell at a premium to other customers. In this arrangement some utilities even pay their net metered customer-generators a premium for the solar power they produce. TVA's Green Power Switch Generation Partners Program is one example.²¹

Refer to Chapter Thirteen to learn more about net metering and purchasing green power in Kentucky.

TVA Purchases PV and Wind Generation from Small Producers

TVA's Green Power Switch Generation Partners Program offers the best solar energy incentives currently available in Kentucky to customers of participating power distributors. TVA will pay \$0.15 per kWh and \$500 upon installation of a new grid-intertied PV or wind generator. See Chapter Thirteen for more information.

Guerilla Solar

What if you live in an area of Kentucky serviced by a municipal electric company that is not responding favorably to your plans to install a net-metered solar electric system? Or what if you were unsuccessful in convincing your TVA power distributor to participate in TVA's Green Power Switch Generation Partners Program? Or maybe you're not interested in jumping through the local utility's regulatory hoops. Many people around the country have confronted obstacles like this by simply not informing their utility that they've installed a grid-intertied PV system.

This phenomenon is known as "guerrilla solar." It developed in response to utilities refusing to cooperate with homeowners wishing to install net-metered solar systems. Many guerilla systems have been installed in areas without net metering and have been approved by

code inspectors, but were then denied approval by the electric utility. Many in this situation have simply gone guerilla and hooked up their systems anyway. If you do install a guerilla system, ensure that it is as safe as an approved, net metered system would be, utilizes UL approved equipment, and meets the National Electric Code.

Although guerilla solar is an option, it should no longer be necessary in most parts of Kentucky now that state law requires all regulated utilities to permit net-metering. For those who are connected to the utility grid but want to avoid dealing with the utility when hooking up a solar system, there remain many ways to utilize solar without "going guerilla." Stand-alone systems of any size can be set up to meet needs independent of the electric grid. These include powering rechargeable batteries, water pumps, computers, outdoor lights, and out-buildings. Beyond solar electric, consider that a solar water heating system connected to an electric water heater will substantially reduce one's electricity consumption. Similarly, using a solar oven will reduce the electricity otherwise used by an electric oven. These all represent easy and legal ways for people to use solar without having to deal with regulatory hassles or paperwork.

End Notes

1. "Photovoltaics: Electricity from the Sun," North Carolina Solar Center, Fact Sheet no. SC108, Raleigh, NC, June 2002, p.1.
2. Joel Makower, Ron Pernick, and Clint Wilder, "Clean Energy Trends 2004," *Clean Edge*, March 2004. Available at www.cleandge.com/reports-trends2004.php
3. "Our Solar Power Future: The US Photovoltaics Industry Roadmap Through 2030 and Beyond," Solar Energy Industries Association, September 2004. Available at: www.seia.org/media/pdfs/pvroadmap.pdf
4. Ibid.
5. "Influential US lawmakers, solar industry leaders share vision for solar power future," Press Release from the Solar Energy Industries Association, Washington, DC, January 28, 2005.
6. "Energy Payback: Clean Energy from PV," National Renewable Energy Laboratory Report, US Department of Energy, NREL Report No. NREL/FS-520-24619), no date.
7. "Overview of Potential Hazards," V.M. Fthenkis, National Photovoltaic Environmental, Health and Safety Assistance Center, Department of Environmental Science, Brookhaven National Laboratory, Upton, NY, 11973. This report and others on this topic are available at www.pv.bnl.gov.
8. "Potential Health and Environmental Impacts

Associated with the Manufacture and Use of Photovoltaic Cells," Electric Power Research Institute, Inc., Palo Alto, CA, Nov. 2003, p.5-1. Report available on-line at: www.epriweb.com/public/000000000001000095.pdf

9. Ibid, p.5-1.
10. Richard Perez, "Myth: Lead-Acid Batteries Wind Up As Toxic Disasters in Our Landfills," Home Power, April/May 2004, no. 100, pp.32-38.
11. Madeleine Cobbing and Simon Divecha, "The Myth of Automobile Battery Recycling," Greenpeace, no date. Available at: www.things.org/~jym/greenpeace/myth-of-battery-recycling.html
12. "Energy Payback: Clean Energy from PV."
13. Ibid.
14. J. Motavalli, "Heavy Metal Harm," E: The Environmental Magazine, May/June 2002, vol.XIII, no.3, p.32.
15. "Photovoltaics: Electricity from the Sun," p.2.
16. SunDanzer's web site is www.SunDanzer.com
17. Joe Schwartz, "Myth: Solar Electricity is too Expensive," Home Power Magazine, April/May 2004, no. 100, p.35.
18. "Photovoltaics: Electricity from the Sun," p.2.
19. "Photovoltaics: Electricity from the Sun," p.3
20. Ibid, p.3.
21. See Chapter Fourteen or visit the web site for the Green Power Switch Program at: www.tva.com/greenpowerswitch/partners/

RESOURCES:

Solar Electric Systems

Publications

- "A Consumer's Guide to Buying a Solar Electric System," National Renewable Energy Laboratory, US Department of Energy, September 1999. Available on-line at www.nrel.gov/ncpv/pdfs/26591.pdf
- "Assessing Climate to Improve Solar Design," Energy Efficiency and Renewable Energy Clearinghouse, US Department of Energy, Document no. DOE/GO-120001-1171, FS122, August 2001. Available on-line at www.eren.doe.gov/
- Consumer Guide to Solar Energy*, S. Sklar & K. Sheinkopf, Bonus Books, Inc., Chicago, 1995.
- Home Power (magazine), see below for contact information.
- "Photovoltaics: Basic Design Principles and Components," Energy Efficiency and Renewable Energy Clearinghouse, U.S. Department of Energy. (DOE/GO-10097-377, FS231), March 1997. Available on-line at www.eren.doe.gov/

"Photovoltaics: Electricity from the Sun," North Carolina Solar Center, Technical Paper no. SC108, North Carolina State University, Raleigh, North Carolina, June 2002. Available at www.ncsc.ncsu.edu

"Siting of Active Solar Collectors and Photovoltaic Modules," North Carolina Solar Center, Technical Paper no. SC112, North Carolina State University, Raleigh, North Carolina, September 2001. Available on-line at www.ncsc.ncsu.edu

The Solar Electric House: Energy for the Environmentally-Responsive, Energy-Independent Home, Steven J. Strong and William G. Scheller, Sustainability Press, 1993.

The Solar Electric Independent Home Book, New England Solar Electric, Inc., Worthington, Massachusetts, 1998.

Solar Today (magazine), American Solar Energy Society, see below for contact information.

The catalogs and web sites produced by solar equipment suppliers are often excellent resources concerning solar equipment and design. Refer to the list of PV equipment suppliers in Chapter Sixteen for more information.

Organizations

American Solar Energy Society

2400 Central Ave
Suite A
Boulder, Colorado 80301
(303)443-3130
www.ases.org

The American Solar Energy Society (ASES) is a national organization dedicated to advancing the use of solar energy for the benefit of U.S. citizens and the global environment. ASES promotes the widespread near- and long-term use of solar energy. Publishers of *Solar Today* magazine (www.solartoday.org).

Florida Solar Energy Center

1679 Clearlake Road
Cocoa, Florida 32922
(321) 638-1000
www.fsec.ucf.edu

The Florida Solar Energy Center researches and promotes energy efficiency and solar energy in Florida. Their site includes project descriptions, on-line research reports, software demonstrations, news and events.

(Continued on next page)

Home Power Magazine

PO Box 520
Ashland, OR 97520
(800)707-6585
(541)512-0201 (outside the U.S.)

www.homepower.com

Home Power is "the hands-on journal of home-made power." Each issue offers in-depth, clearly-written, well-illustrated articles discussing the entire array of renewable energy technologies, educating and empowering their readers toward more sustainable lifestyles.

Midwest Renewable Energy Association

7558 Deer Road
Custer, WI 54423
Phone: (715)592-6595

www.the-mrea.org

The Midwest Renewable Energy Association offers workshops and training that cover a variety of topics related to renewable energy. Their annual Renewable Energy Fair, held each year on the summer solstice in Wisconsin, offers excellent educational and networking opportunities, and is billed as the largest RE Fair in the country.

National Renewable Energy Laboratory

www.nrel.gov

The National Renewable Energy Laboratory is the nation's leading center for renewable energy research. Their web site features publications, program and project descriptions, partnership opportunities, news and events.

North Carolina Solar Center

Box 7401
North Carolina State University
Raleigh, NC 27695-7401
(919)515-5666

www.ncsc.ncsu.edu

The North Carolina Solar Center serves as a clearinghouse for solar and other renewable energy programs, information, research, technical assistance, and training for the citizens of North Carolina and beyond. The Center offers numerous publications addressing passive and active solar energy. These documents can be downloaded for free from their web site (follow the link for "Information Resources"). They will also mail printed copies to those who do not have access to the internet.

Solar Energy Industries Association

805 15th Street, NW
Suite 510
Washington, DC 20005
(202) 682 - 0556

www.seia.org

The Solar Energy Industries Association (SEIA) is the national trade association of solar energy manufacturers, dealers, distributors, contractors, installers, architects, consultants, and marketers. They work to expand the use of solar technologies in the global marketplace. On their web site you can find out how to get involved as an individual or a solar business, keep up on the latest solar policy news, and find out about contractors and incentives for buying solar yourself.

Solar Energy International

PO Box 715
76 S. 2nd St.
Carbondale, CO 81623
(970)963-8855

www.solarenergy.org

Solar Energy International (SEI) offers hands-on workshops in solar, wind and water power and natural building technologies in eleven locations. SEI also offers internet-based online courses.